

Float control to valve type No. 1603 and No. 1604

1980

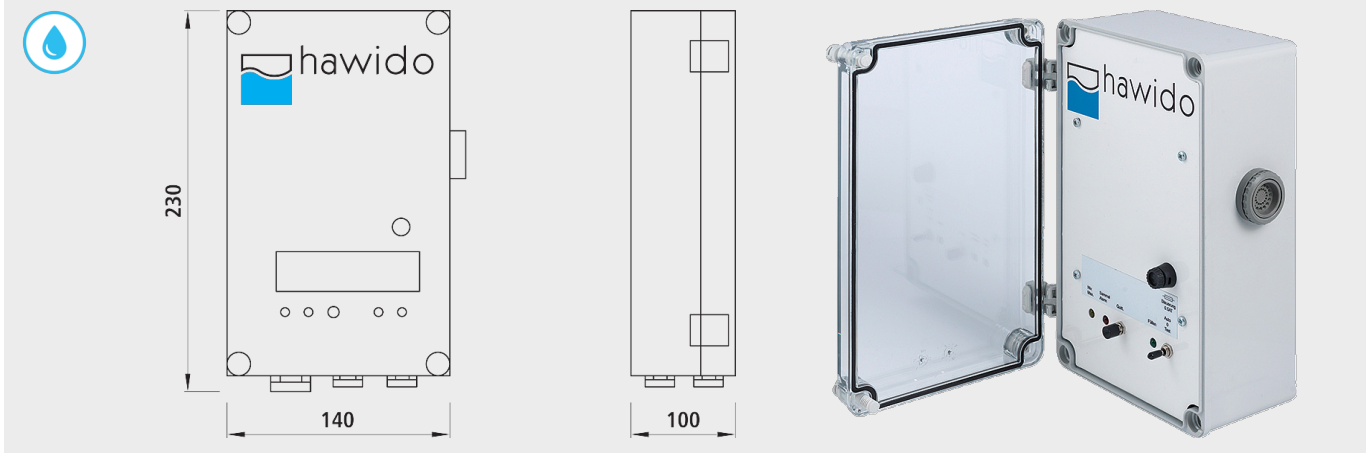

Product information

- The control is used for valves (No. 1603 und No.1604). These regulate the water level in the reservoir by means of the inclined float switches.

Characteristics

- Plastic boxes with a see/through in the following size: W x H x D = 140 x 230 x 100 mm
- Housing IP 65
- Operation Test-0-Auto
- Operation display (open), maximum level general alarm
- Connections for floats In, Out, Alarm, Solenoid valve, Feed
- Alarm in the control: Horn
- Feed 230 VAC
- Valve 24 VDC, relay changeover contact

	weight (kg)
1980603A0A	1.300